

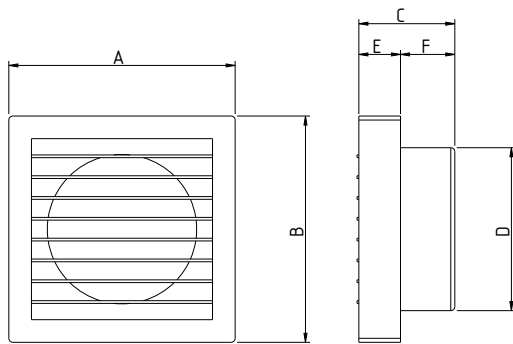

VENTILAIR DX-WE

- Modern design, fashionable and elegant look
- Suitable for window & wall mounted indoor installation
- Electrically operated automated front shutter



Sweep	A	B	C	D	E	F
150 mm	208 mm	208 mm	120 mm	146 mm	58 mm	62 mm

Sweep	Power Input	Speed	Air Delivery	Rated Voltage	Rated Frequency	Noise Level
150 mm	25 W	1760 r/min (RPM)	300 m ³ /h	220 V-240 V	50 Hz	45 dB

Note: Also available with thermally operated automatic shutter (DX-WT)



VENTILAIR BLDC



- Easy installation on glass window & wood panels
- Powerful air suction for clean and odorless air
- Mosquito net to avoid entry of insects
- Very low noise

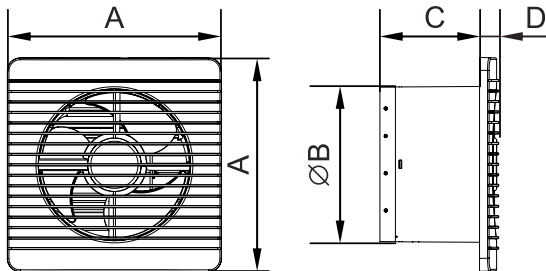

Sweep	A	B	C	D	Cut out space for installation Ø A
150 mm	200 mm	147 mm	93.5 mm	18 mm	153 mm
200 mm	250 V	180 mm	128 mm	11 mm	184 mm

Sweep	Power Input	Speed	Air Delivery	Rated Voltage	Rated Frequency	Noise Level
150 mm	5 W	1760 r/min (RPM)	180 m ³ /h	220 V-240 V	50 Hz	40 dB
200 mm	6 W	1760 r/min (RPM)	252 m ³ /h	220 V-240 V	50 Hz	40 dB



VENTILAIR DXW

- Modern design, fashionable & elegant look
- Ideal for mounting on glass window & wood panels

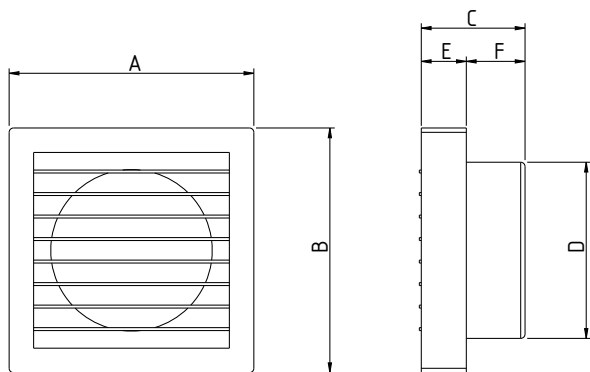

Sweep	A	B	C	D	E	F	Sweep	Power Input	Speed	Air Delivery	Rated Voltage	Rated Frequency	Noise Level
100 mm	150 mm	150 mm	81 mm	97 mm	35 mm	46 mm	100 mm	15 W	2400 r/min (RPM)	100 m ³ /h	220 V-240 V	50 Hz	43 dB
150 mm	208 mm	208 mm	106 mm	146 mm	46 mm	60 mm	150 mm	25 W	2000 r/min (RPM)	300 m ³ /h	220 V-240 V	50 Hz	45 dB



VENTILAIR DXR

- Back shutter & fan "ON-OFF" operations are inter-locked through pull cord
- Easy installation on glass & wood panels

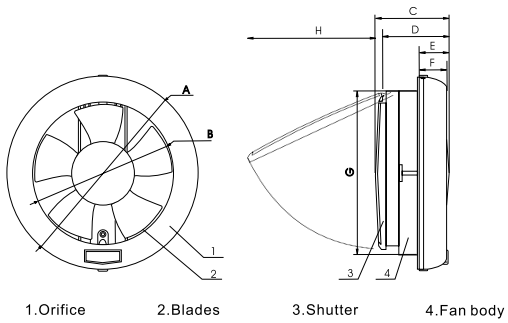

Sweep	A	B	C	D	E	F	G	H
150 mm	210 mm	150 mm	80 mm	72 mm	35 mm	32 mm	180 mm	142 mm

Sweep	Power Input	Speed	Air Delivery	Rated Voltage	Rated Frequency	Noise Level
150 mm	25 W	1800 r/min (RPM)	300 m ³ /h	220 V-240 V	50 Hz	45 dB



VENTILAIR HUSH

- Modular concept
- High suction capacity
- Noiseless operation
- Removable front plate for easy cleaning

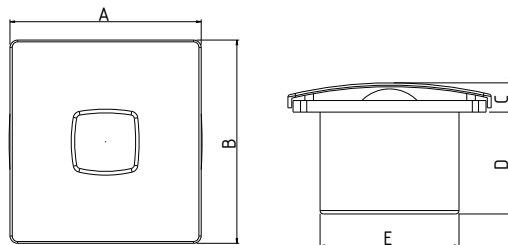

Sweep	A	B	C	D	E
100 mm	150 mm	150 mm	27 mm	72 mm	98 mm
150 mm	200 mm	200 mm	28 mm	94 mm	145 mm

Sweep	Power Input	Speed	Air Delivery	Rated Voltage	Rated Frequency	Noise Level
100 mm	15 W	2450 r/min (RPM)	140 m ³ /h	220 V-240 V	50 Hz	35 dB
150 mm	25 W	2000 r/min (RPM)	275 m ³ /h	220 V-240 V	50 Hz	40 dB



VENTILAIR DXZ NEO

- Easy installation on glass / window panels
- High quality plastic, resistant to colour change
- Elegant front grill
- Also available in black color

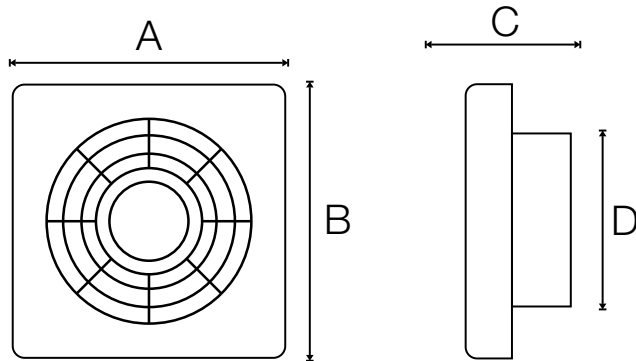

Sweep	A	B	C	D
150 mm	165 mm	165 mm	115 mm	68 mm

Sweep	Power Input	Speed	Air Delivery	Rated Voltage	Rated Frequency	Noise Level
150 mm	25 W	2000 r/min (RPM)	250 m ³ /h	220 V-240 V	50 Hz	45 dB



VENTILAIR DX

- Ideal for mounting on wood
- High quality engineering plastic, resistant to colour change with anti-static properties

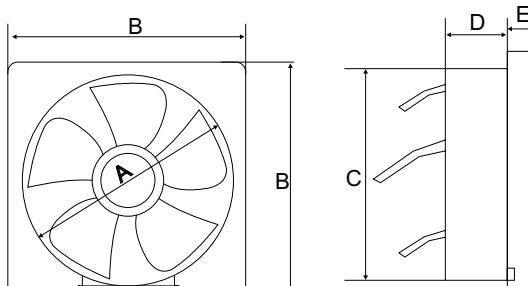

Sweep	A	B	C	D	E
150 mm	150 mm	241 mm	172 mm	73 mm	50 mm
200 mm	200 mm	298 mm	240 mm	90 mm	40 mm
250 mm	250 mm	348 mm	290 mm	90 mm	48 mm

Sweep	Power Input	Speed	Air Delivery	Rated Voltage	Rated Frequency	Noise Level
150 mm	25 W	1350 r/min (RPM)	280 m ³ /h	220 V-240 V	50 Hz	40 dB
200 mm	32 W	1350 r/min (RPM)	520 m ³ /h	220 V-240 V	50 Hz	45 dB
250 mm	35 W	1200 r/min (RPM)	860 m ³ /h	220 V-240 V	50 Hz	48 dB



VENTILAIR DX - HS

- Ideal for mounting on wood
- High quality engineering plastic, resistant to colour change with anti-static properties

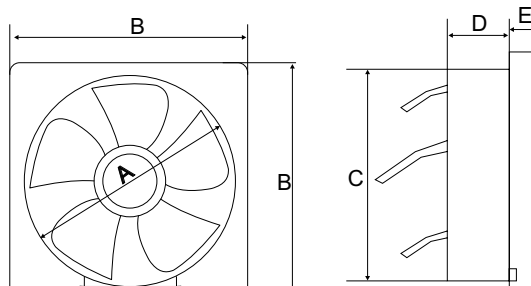

Sweep	A	B	C	D	E
150 mm	150 mm	241 mm	172 mm	73 mm	50 mm
200 mm	200 mm	298 mm	240 mm	90 mm	40 mm

Sweep	Power Input	Speed	Air Delivery	Rated Voltage	Rated Frequency	Noise Level
150 mm	30 W	2300 r/min (RPM)	600 m ³ /h	220 V-240 V	50 Hz	60 dB
200 mm	65 W	2000 r/min (RPM)	850 m ³ /h	220 V-240 V	50 Hz	60 dB



VENTILAIR LX

- Modern design, fashionable and elegant look
- Ideal for mounting on glass window and wooden panels

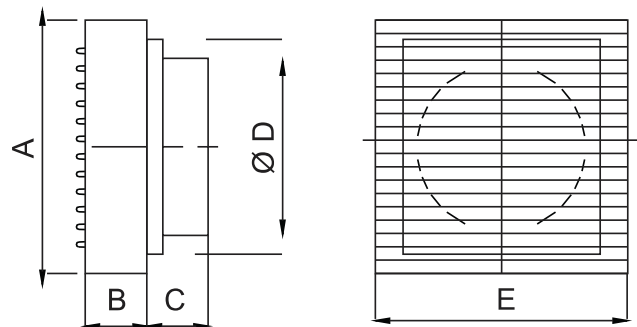

Sweep	A	B	C	D	E
150 mm	208 mm	21 mm	90 mm	150 mm	208 mm
200 mm	255 mm	22 mm	90 mm	200 mm	255 mm

Sweep	Power Input	Speed	Air Delivery	Rated Voltage	Rated Frequency	Noise Level
150 mm	22 W	2000 r/min (RPM)	280 m ³ /h	220 V-240 V	50 Hz	50 dB
200 mm	35 W	1800 r/min (RPM)	500 m ³ /h	220 V-240 V	50 Hz	50 dB



THRILL AIR DX

- Rust proof body and blades
- Automatic shutter
- Durable motor

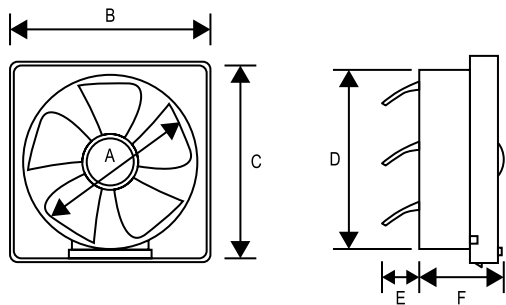

Sweep	A	B	C	D	E	F
150 mm	150 mm	244 mm	212 mm	191 mm	65 mm	125 mm
200 mm	200 mm	294 mm	262 mm	241 mm	70 mm	101 mm
250 mm	250 mm	344 mm	312 mm	291 mm	69 mm	115 mm

Sweep	Power Input	Speed	Air Delivery	Rated Voltage	Rated Frequency	Noise Level
150 mm	24 W	1370 r/min (RPM)	270 m ³ /h	220 V-240 V	50 Hz	40 dB
200 mm	28 W	1350 r/min (RPM)	500 m ³ /h	220 V-240 V	50 Hz	45 dB
250 mm	36 W	1300 r/min (RPM)	800 m ³ /h	220 V-240 V	50 Hz	48 dB



THRILL AIR - DX HS

- Rust proof body and blades
- Automatic shutter
- Durable motor

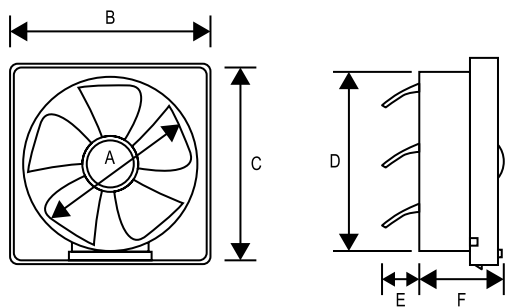

Sweep	A	B	C	D	E	F
150 mm	150 mm	244 mm	212 mm	191 mm	65 mm	125 mm
200 mm	200 mm	294 mm	262 mm	241 mm	70 mm	101 mm

Sweep	Power Input	Speed	Air Delivery	Rated Voltage	Rated Frequency	Noise Level
150 mm	55 W	2500 r/min (RPM)	650 m ³ /h	220 V-240 V	50 Hz	60 dB
200 mm	65 W	2000 r/min (RPM)	800 m ³ /h	220 V-240 V	50 Hz	60 dB



VENTILAIR DB

- Double ball bearings
- Heavy duty motor
- Protective steel bird guard
- Robust construction



Sweep	Power Input	Speed	Air Delivery	Rated Voltage	Rated Frequency	Noise Level
230 mm	45 W	1400 r/min (RPM)	860 m ³ /h	220 V-240 V	50 Hz	45-50 dB
300 mm	70 W	1400 r/min (RPM)	1850 m ³ /h	220 V-240 V	50 Hz	45-50 dB



VENTILAIR DS

- Specially designed metal blade
- Powder coated long lasting finish
- Sturdy steel bird guard



Sweep	Power Input	Speed	Air Delivery	Rated Voltage	Rated Frequency	Noise Level
150 mm	38 W	2800 r/min (RPM)	400 m ³ /h	220 V-240 V	50 Hz	45-50 dB
230 mm	35 W	1400 r/min (RPM)	800 m ³ /h	220 V-240 V	50 Hz	45-50 dB
300 mm	40 W	1400 r/min (RPM)	1060 m ³ /h	220 V-240 V	50 Hz	45-50 dB



VENTILAIR DSP

- Specially designed metal blade
- Powder coated long lasting finish
- Sturdy steel bird guard



Sweep	Power Input	Speed	Air Delivery	Rated Voltage	Rated Frequency	Noise Level
150 mm	30 W	1400 r/min (RPM)	300 m ³ /h	220 V-240 V	50 Hz	45-50 dB
230 mm	40 W	1350 r/min (RPM)	510 m ³ /h	220 V-240 V	50 Hz	45-50 dB
300 mm	50 W	1350 r/min (RPM)	900 m ³ /h	220 V-240 V	50 Hz	45-50 dB



VENTILAIR DS HS

REVERSIBLE

- Specially designed metal blades
- Powder coated for long lasting finish
- Sturdy steel bird guard



Sweep	Power Input	Speed	Air Delivery	Rated Voltage	Rated Frequency	Noise Level
230 mm	65W	2300 r/min (RPM)	1050 m ³ h	220 V - 240 V	50 Hz	68 dB
300 mm	75 W	2300 r/min (RPM)	1533 m ³ h	220 V - 240 V	50 Hz	70 dB